

## INSTALLATION INSTRUCTIONS

# 263P/354P POWERTRAK MOUNTING BRACKET KITS

**Part No. 033342 for 263P PowerTrak...Part No. 033343 for 354P PowerTrak**

Each Mounting Bracket Kit includes two left hand brackets and two right hand brackets, four cover plates, four bushings, four spacers, and all hardware required for attaching brackets to PowerTrak. Study these instructions carefully to learn where each bracket, bushing and spacer goes. Hardware for affixing PowerTrak to support is not included.

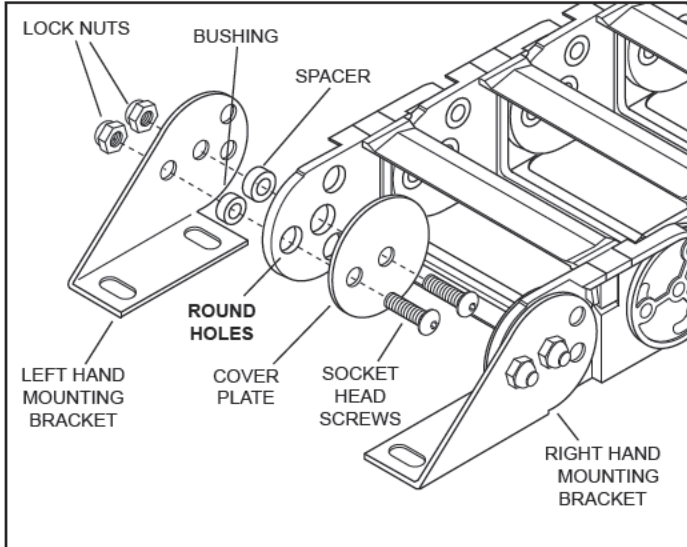

**FIXED END of POWERTRAK**

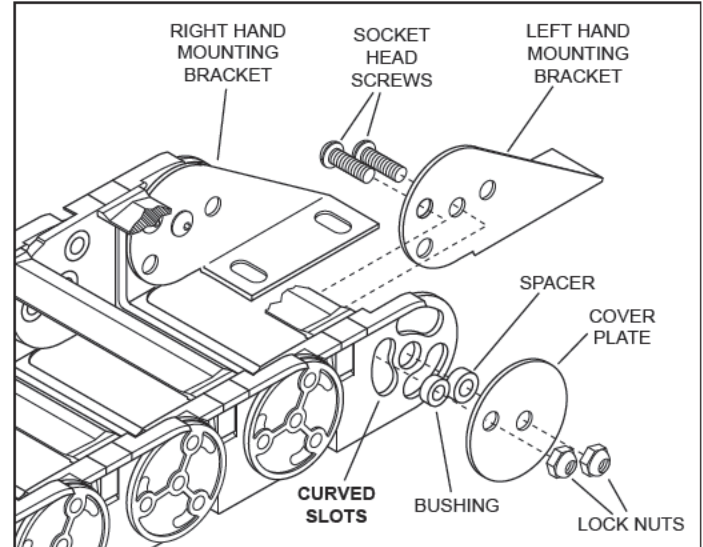

**MOVING END of POWERTRAK**

### INSTALLATION

1. Identify all parts in kit:
  - A. Brackets are either left hand or right hand as shown in illustrations above.
  - B. Bushings have a slightly smaller outside diameter than the spacers. The spacers fit snugly into the center hole and will not fit into the three outer holes nor the kidney shaped slots. The bushings, however, fit snugly into the outer holes and slots (loose in center hole). Be sure to use spacers in center hole only and bushings only in the holes (fixed end) or slots (moving end).

2. Assemble per illustrations above.

#### CAUTION

Heads of socket head screws must be toward inside of PowerTrak, as shown, to prevent interference with cable or hose.

#### NOTES:

- A. Brackets may also be mounted with flanges facing outward, if required (Fig. 1).
- B. In certain applications, brackets must be mounted perpendicular (90°) to track links (Fig 2). Note that alternate holes are used for the bolts with bushings as shown at right.

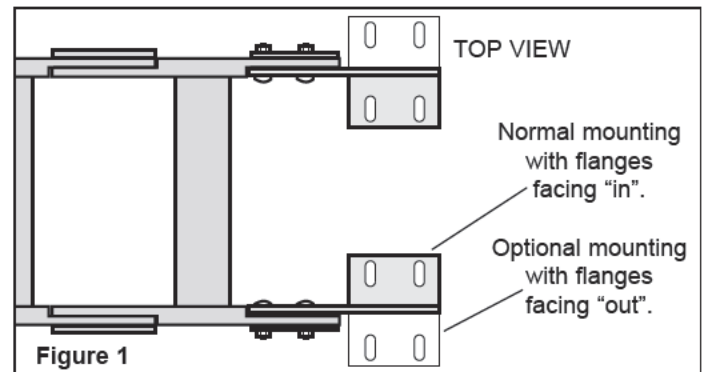

**Figure 1**

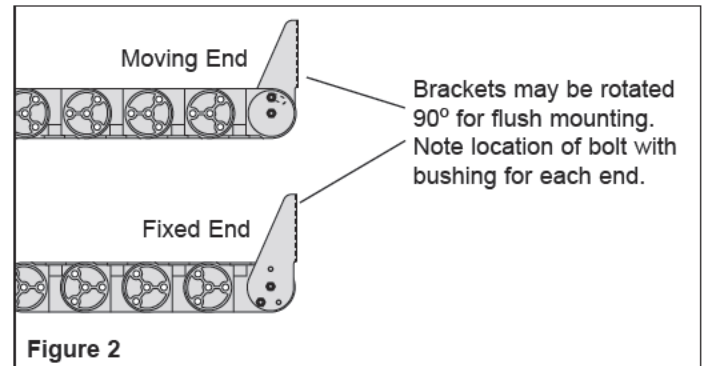

**Figure 2**



### Gleason Reel Corp.

600 S. Clark St.  
Mayville, Wisconsin 53050-0026  
Phone 920-387-4120  
FAX 920-387-4189



## Zampini Industrial Group

Trusted Industrial Suppliers Since 1986

85 Industrial Circle, Suite 2211

Lincoln, RI 02865

USA

Factory Authorized Gleason Reel Suppliers  
FAST Quotes, FAST Delivery!



### ZAMPINI INDUSTRIAL GROUP



Contact Us For Your Gleason Reel Products and Parts Today!

Email Us

Call Us

Fax Us



[info@AirToolPro.com](mailto:info@AirToolPro.com)

1-800-353-4676  
1-401-305-7997

1-401-305-7988



**We Respond FAST!**  
Minimize Your Downtime!



Numerous Ways To Get Pricing



**Guaranteed Satisfaction!**  
Excellent Service Since 1967!



Everyday Discounts  
Quantity Discounts  
Email Specials  
Low Price Guarantee