

GLEASON PowerFlex

The fully modular, fully enclosed cable/hose carrier

Modular design makes it possible to alter the carrier's length, on site, in minutes. The unique construction allows complete flexibility in designing your machine travel and simplifies installing carriers on machines where required carrier length is not known.

In addition to altering overall length, it is possible to repair PowerFlex while it is installed on your machine...without having to disconnect hoses or cables or the PowerFlex itself. Repairs can be made in minutes without having to pull out every hose/cable or replace the entire carrier.

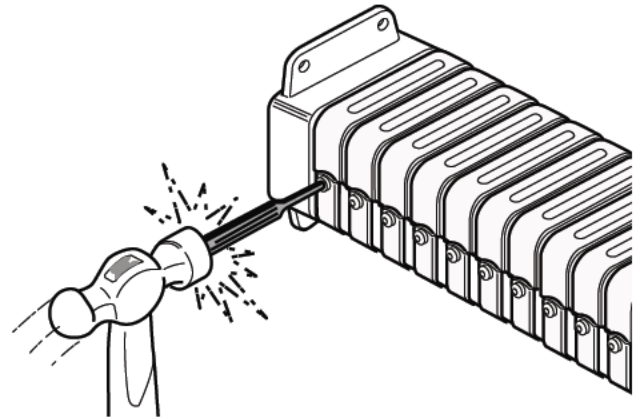
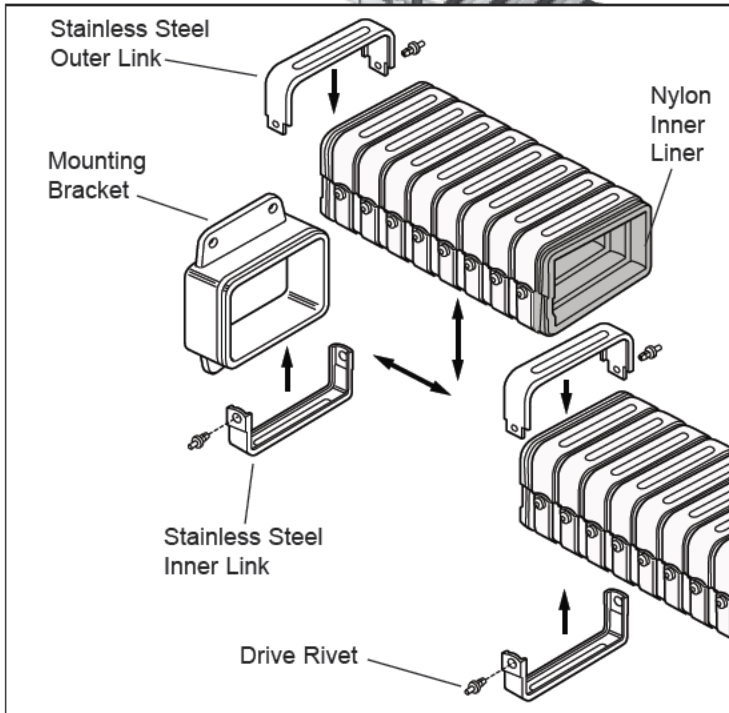

To shorten or lengthen PowerFlex, use a 3/32" punch to drive posts out of rivets securing mounting bracket (above) or links (below). Add or remove links as required. Insert new drive rivets and seat post with hammer as shown in lower left illustration. To repair damaged PowerFlex, remove damaged links and replace. Repairs can be easily made without removing and restringing cables or hoses because nylon inner liners in repair kits are split.

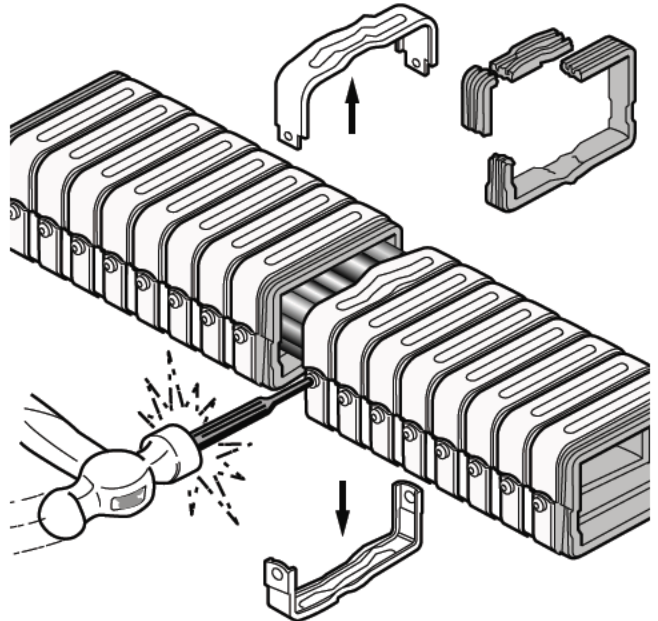
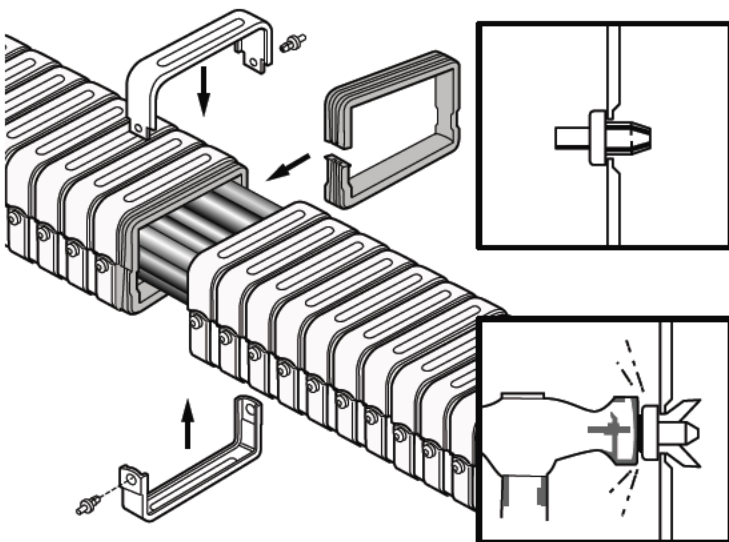

Gleason Reel Corp.

600 South Clark St.
Mayville, WI 53050
Phone: 920-387-4120
Fax: 920-387-4189

Part No. 048791.a



Zampini Industrial Group

Trusted Industrial Suppliers Since 1986

85 Industrial Circle, Suite 2211

Lincoln, RI 02865

USA

Factory Authorized Gleason Reel Suppliers
FAST Quotes, FAST Delivery!



ZAMPINI INDUSTRIAL GROUP



Contact Us For Your Gleason Reel Products and Parts Today!

Email Us

Call Us

Fax Us



info@AirToolPro.com

1-800-353-4676
1-401-305-7997

1-401-305-7988



We Respond FAST!
Minimize Your Downtime!



Numerous Ways To Get Pricing



Guaranteed Satisfaction!
Excellent Service Since 1967!



Everyday Discounts
Quantity Discounts
Email Specials
Low Price Guarantee