

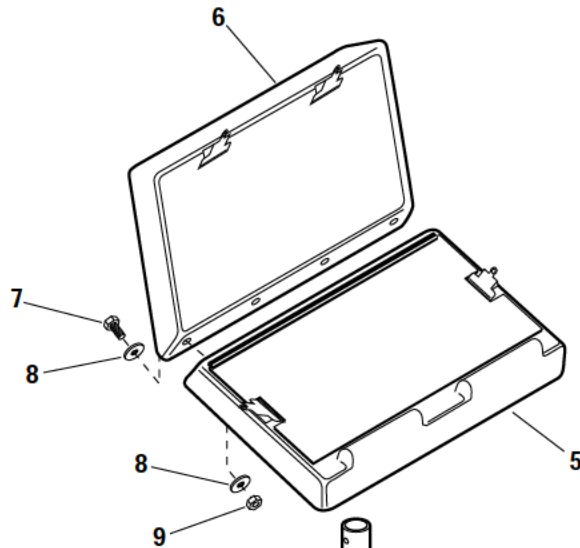

Assembly Instructions 900S, 1000S & 1500S Document Stand 1600S Message Board



NOTE: This stand may be assembled with writing surface (item 5) at a height suitable for either standing use or seated use. To assemble for seated use, substitute 11" long post section for 22 1/2" long section (item 2).

Refer to illustration at left. *NOTE: The unit you are assembling may look slightly different than the illustration.*

1. Identify posts for stand (item 2).
2. Slide end of lower post (2) into base (1). Secure with screw, nut (3) and two setscrews. Slide upper post into top of lower post. Secure with screw and nut (4). Tighten all securely.
3. Snap glides into base (1).
4. Slide writing panel onto top of stand post (detail 1). Secure with screw and nut (C on detail 1). Tighten.
5. Assemble display panel (6) to writing panel (5) using four bolts, flat washers and hex nuts (7, 8, 9). Tighten securely.
6. Remove protective sheets from clear acrylic covers by running knife blade along edge of hinge and stripping off tinted plastic.

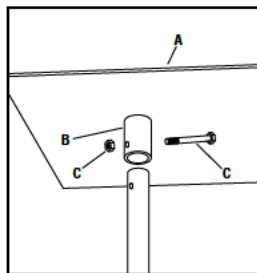

-Detail 1-
Assembling writing
surface to post.

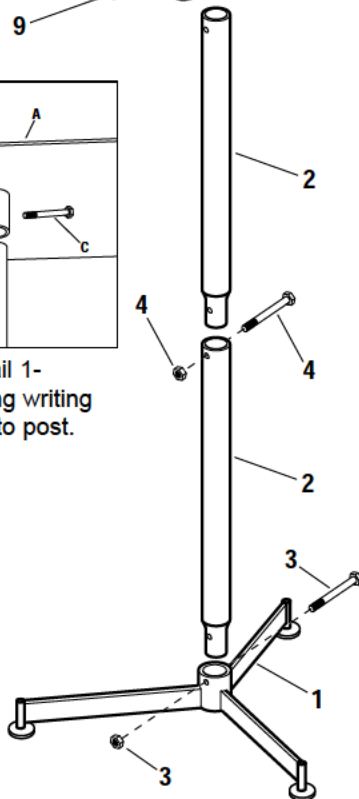

Workplace Solutions

600 South Clark St.
Mayville, WI 53050
Phone: 920-387-4120
Fax: 920-387-4189
www.hubbell.com/gleasonreel/en



Zampini Industrial Group

Trusted Industrial Suppliers Since 1986

85 Industrial Circle, Suite 2211

Lincoln, RI 02865

USA

Factory Authorized Gleason Reel Suppliers
FAST Quotes, FAST Delivery!



ZAMPINI INDUSTRIAL GROUP



Contact Us For Your Gleason Reel Products and Parts Today!

Email Us

Call Us

Fax Us



info@AirToolPro.com

1-800-353-4676
1-401-305-7997

1-401-305-7988



We Respond FAST!
Minimize Your Downtime!



Numerous Ways To Get Pricing



Guaranteed Satisfaction!
Excellent Service Since 1967!



Everyday Discounts
Quantity Discounts
Email Specials
Low Price Guarantee