

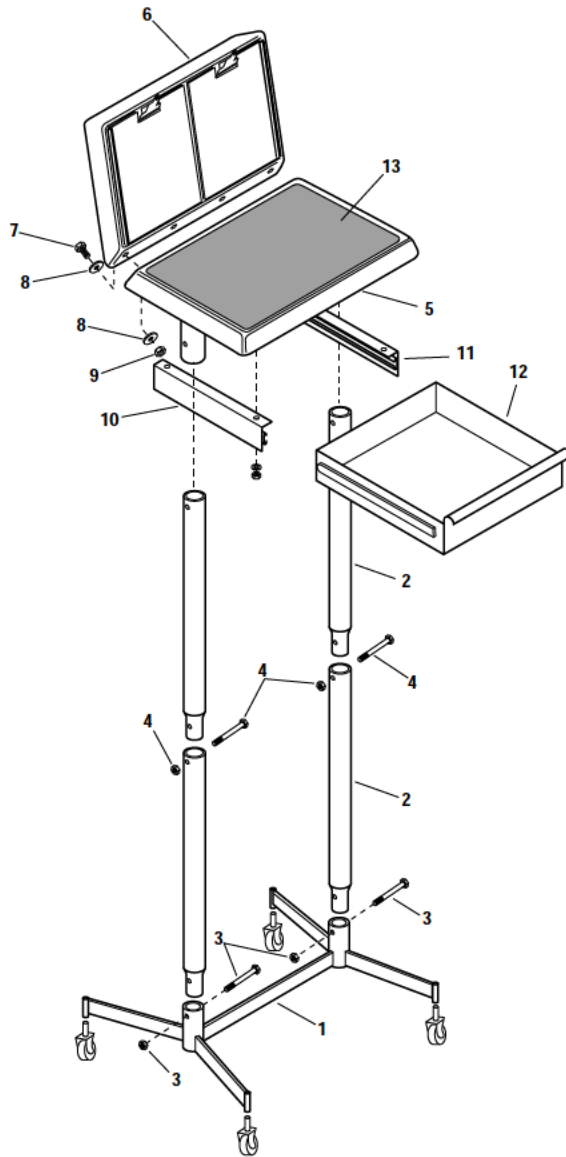

Assembly Instructions 2700D Inspection Stand



NOTE: This stand may be assembled with writing surface (item 5) at a height suitable for either standing use or seated use. To assemble for seated use, substitute 11" long post section for 22 1/2" long section (item 2).

Refer to illustration at left. *NOTE: The unit you are assembling may look slightly different than the illustration.*

1. Identify posts for stand (items 2).
2. Snap casters into base (1).
3. Slide ends of lower posts (2) onto base (1). Secure with screws, nuts (3) and setscrews. Slide upper posts into tops of lower posts. Secure with screws and nuts (4). Tighten all securely.
4. Remove the four 1/4" - 20 nuts from plate on underside of 20" x 26" inspection panel (5). Mount drawer adapters (10 & 11) to plate and replace nuts.
NOTE: Mounting flanges of adapters must be facing each other.
5. Slide inspection panel (5) onto top of stand posts (detail 1). Secure with screw and nut in each sleeve (C on detail 1). Tighten
6. Slide drawer (12) into glide mechanisms on drawer adapters (10 & 11).
NOTE: make sure ball bearings are fully engaged and not cocked or drawer will not stay in grooves.
7. Attach display panel (6) to inspection panel (5) using four bolts, flat washers and hex nuts (7, 8, 9). Tighten securely.
8. Install neoprene pad (item 13) on inspection panel.
9. Remove protective sheets from clear acrylic covers by running knife blade along edge of hinge and stripping off tinted plastic.

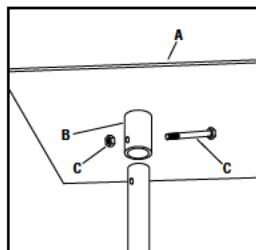

-Detail 1-
Assembling inspection
panel to post.



Workplace Solutions

600 South Clark St.
Mayville, WI 53050
Phone: 920-387-4120
Fax: 920-387-4189
www.hubbell.com/gleasonreel/en

Part No. 2693.c



Zampini Industrial Group

Trusted Industrial Suppliers Since 1986

85 Industrial Circle, Suite 2211

Lincoln, RI 02865

USA

Factory Authorized Gleason Reel Suppliers
FAST Quotes, FAST Delivery!



ZAMPINI INDUSTRIAL GROUP



Contact Us For Your Gleason Reel Products and Parts Today!

Email Us

Call Us

Fax Us



info@AirToolPro.com

1-800-353-4676
1-401-305-7997

1-401-305-7988



We Respond FAST!
Minimize Your Downtime!



Numerous Ways To Get Pricing



Guaranteed Satisfaction!
Excellent Service Since 1967!



Everyday Discounts
Quantity Discounts
Email Specials
Low Price Guarantee