

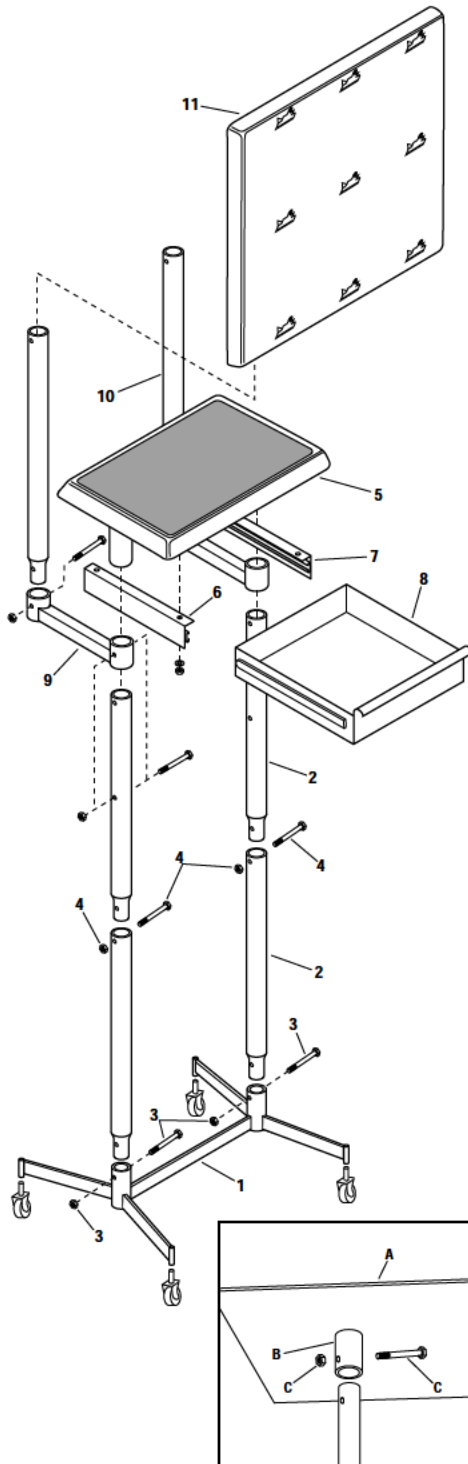

Assembly Instructions 2750D Inspection Stand



-Detail 1-
Assembling inspection
panel to posts.

NOTE: This stand may be assembled with writing surface (item 5) at a height suitable for either standing use or seated use. To assemble for seated use, substitute 11" long post section for 22 1/2" long section (item 2).

Refer to illustration at left. *NOTE: The unit you are assembling may look slightly different than the illustration.*

1. Identify posts for stand (item 2).
2. Slide end of lower post (2) into base (1). Secure with screw, nut (3) and setscrews. Slide upper post into top of lower post. Secure with screw and nut (4). Tighten all securely.
3. Install casters.
4. Slip mounting arms (9) onto ends of stand posts. Secure with screw and nut. Tighten.
5. Remove the four 1/4" - 20 nuts from plate on underside of 20" x 26" inspection panel (5). Mount drawer adapters (6 & 7) to plate and replace nuts.
NOTE: Mounting flanges of adapters must be facing each other.
6. Slide inspection panel (5) onto top of stand posts (detail 1). Secure with screw and nut. Tighten (C on detail 1).
7. Slip tubes (10) into mounting arms (9). Secure with screw and nut. Tighten.
8. Slip mounting sleeves on back of display panel (11) onto tops of tubes. Secure with screw and nut. Tighten.
9. Slide drawer (8) into glide mechanisms on drawer adapters (6 & 7).
NOTE: make sure ball bearings are fully engaged and not cocked or drawer will not stay in grooves.
10. Install neoprene pad on inspection panel.



Workplace Solutions

Gleason Reel Corp.

600 South Clark St.
Mayville, WI 53050
Phone: 920-387-4120 • Fax: 920-387-4189
www.hubbell.com/gleasonreel/en

Part No. 2694.c



Zampini Industrial Group

Trusted Industrial Suppliers Since 1986

85 Industrial Circle, Suite 2211

Lincoln, RI 02865

USA

Factory Authorized Gleason Reel Suppliers
FAST Quotes, FAST Delivery!



ZAMPINI INDUSTRIAL GROUP



Contact Us For Your Gleason Reel Products and Parts Today!

Email Us

Call Us

Fax Us



info@AirToolPro.com

1-800-353-4676
1-401-305-7997

1-401-305-7988



We Respond **FAST!**
Minimize Your Downtime!



Numerous Ways To Get Pricing



Guaranteed Satisfaction!
Excellent Service Since 1967!



Everyday Discounts
Quantity Discounts
Email Specials
Low Price Guarantee