



Assembly and Use Instructions Monitor, CPU and Printer Enclosures

Enclosures are shipped assembled except for attaching monitor hood to monitor enclosure wrapper, snapping monitor enclosure wrapper to CPU enclosure or base, removing plastic film from acrylic face plate, and cutting cable grommet to fit CPU and/or monitor power cords.

Attaching Monitor Enclosure Wrapper

Ball studs and clips are provided for ease of attaching or removing monitor enclosure wrapper. To attach wrapper, simply position clips over ball studs (Fig. 1) and snap in place. Press down on each corner to engage the seal. When removing wrapper, 18 lbs. of pressure is required to release the clips. Apply pressure in the upper corners of the enclosure wrapper. Threaded holes are provided in the center flanges of the wrapper for slotted screws (included) if further security is required.

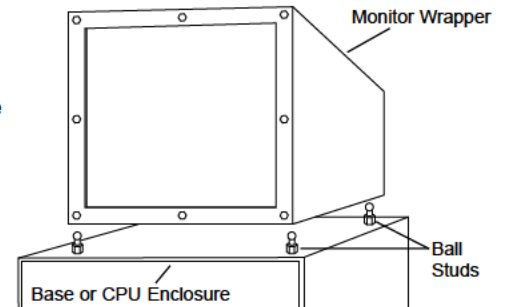

Figure 1-Attaching Wrapper

Attaching Monitor Hood to Wrapper

Remove screws holding the acrylic face plate. Tear off clear plastic film on both sides. Mount monitor hood on the outside of the face plate and replace the screws (Fig. 2).

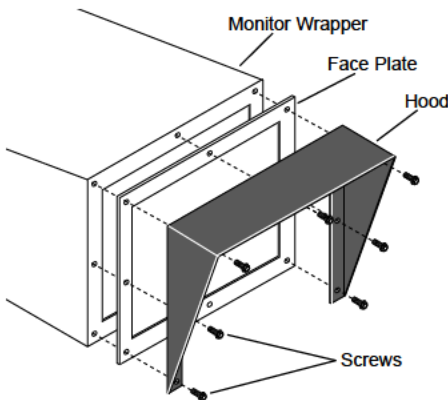

Figure 2-Attaching Hood

Cutting Cable Grommet and Installing Cables

1. Remove cable grommet holder from back panel (refer to Figure 3).
2. Remove neoprene grommet from the holder.
3. Drill a hole for each cable using a drill slightly smaller than cable. Holes should be in center of grommet, approximately 1/2" apart. Make sure holes are positioned so grommet holder will not interfere with cables.
4. Using a sharp knife or hacksaw, make a cut from each hole to the outside of the grommet.
5. After placement of electronics inside enclosure, string through opening in back panel to outside.

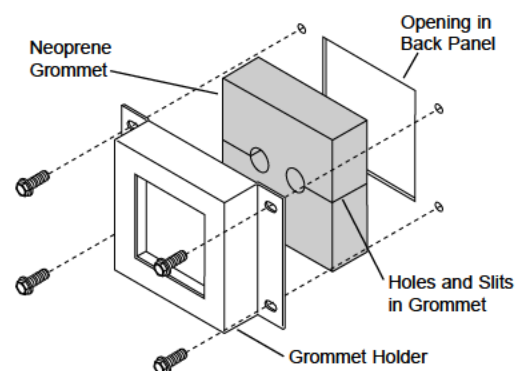

Figure 3-Cable Grommet

6. Slip cables through grommet to the drilled holes and replace the grommet in the holder, compressing it around the cables.
7. Reattach the holder onto the back panel.

Installing Surge Suppressor

Multiple outlet surge suppressors are shipped loose to allow individual placement by end user. Double-sided tape has been applied to back of surge suppressor for application convenience. Remove plastic cover and apply suppressor where appropriate.

Grounding

Green ground screws are located on the back of each unit.

Please See Special Instructions for Individual Models on Opposite Side

Fan and Filter Maintenance

Filters should be checked and cleaned with soap and water or replaced on a scheduled basis depending on shop environment. Replacement filters are available from Hubbell Workplace Solutions.



Instructions for Individual Models

QCS3000: Monitor cable and power cords enter computer enclosure through grommet covering rectangular hole in rear. (See instructions for drilling and cutting grommet to fit your cables on front side of this sheet.) Keyboard cable is routed through slot on right side of inner frame beside the plastic door in front. Remove cover, insert cable and replace cover. Mouse cable on a PC **should exit through grommet in back panel** to avoid crimping cable.

QCS3100: Cable from computer keyboard should be routed through grommet in bottom of monitor enclosure. (See instructions for drilling and cutting grommet to fit your cables on front side of this sheet.)

QCS3200: Route cable from keyboard to computer keyboard through grommet in top of keyboard enclosure.

QCS3500: CAUTION...In older models, height adjustable glides may interfere with fan housing and should not be set less than 3" from bottom of housing.

QCS7000: Mount swing arm into vertical tube in rear center of work surface. Mount bottom monitor tray onto swing arm. Place monitor on tray and hold down with Velcro strips. Route monitor cables through grommet in the bottom of the monitor tray and back into the lower computer cabinet through grommet in the lower back panel.

NOTE: Cable extensions may be required depending on height of monitor and location of components in the large enclosure. Keyboard cables to computer are routed through grommet located on the inside of the keyboard enclosure at the back. Access is through the top, back panel. Adjust shelf in lower computer cabinet as appropriate. Grommet at lower left of back panel is for surge suppressor cable and plug.

Replacement Parts for Enclosures

| Miscellaneous | | | |
|------------------------------------|----------|----------|--|
| Description | Qty/Pack | Part No. | |
| 4.5" 88/110 cfm Fan | 1 | 1245 | |
| Fan Guard for 4.5" Fan | 1 | 1249 | |
| Media Retainer for 4.5" Fan | 1 | 1248 | |
| Power Cord for Fan | 1 | 1371 | |
| Hips Bezel-14"/15" (old style) | 1 | 0293 | |
| Hips Bezel-14"/15" (new style) | 1 | 0340 | |
| Vivac Window & Tape (old style) | 1 | 2090 | |
| Vivac Window & Tape (new style) | 1 | 2091 | |
| Adjustable Glides-Long Stem | 1 | 1297 | |
| Neoprene Grommet-1" x 3" x 9" | 1 | 522 | |
| Black Hips Work Surface-Model 7000 | 1 | 0670 | |
| Acrylic Door -Model 7000 | 1 | 1384 | |
| CPU Acrylic Door-QCS3000 | 1 | 1757 | |
| CPU Acrylic Door-QCS3100 | 1 | 1319 | |

| Filter/Media Assemblies | | | |
|--------------------------------|----------|----------|--|
| Description | Qty/Pack | Part No. | |
| 30 PPI Filter for 3" Fan | 5 | 1237 | |
| 45 PPI Filter for 3" Fan | 5 | 1240 | |
| 60 PPI Filter for 3" Fan | 5 | 1241 | |
| 100 PPI Filter for 3" Fan | 5 | 1244 | |
| 30 PPI Filter for 4.5" Fan | 5 | 1247 | |
| 45 PPI Filter for 4.5" Fan | 5 | 1251 | |
| 60 PPI Filter for 4.5" Fan | 5 | 1252 | |
| 100 PPI Filter for 4.5" Fan | 5 | 1255 | |

| Locks | | | |
|---|----------|----------|--|
| Description | Qty/Pack | Part No. | |
| Inner Cam Lock for QCS3000 | 1 | 1291 | |
| Link Lock for QCS3000 | 1 | 1309 | |
| T-Handle Lock for QCS7000 | 1 | 1234 | |
| Cam Lock for QCS7000 Keyboard and Workstand Utility Trays | 1 | 0828 | |

| Neoprene Liners for QCS7000 | | | |
|------------------------------------|----------|----------|--|
| Description | Qty/Pack | Part No. | |
| Liner for Work Surface | 1 | 0514 | |
| For Shelves | 2 | 0515 | |
| For Bottom | 1 | 0516 | |
| For Keyboard Tray | 1 | 0621 | |



Workplace Solutions

600 South Clark St.
 Mayville, WI 53050
 Phone: 920-387-4120
 Fax: 920-387-4189



Zampini Industrial Group

Trusted Industrial Suppliers Since 1986

85 Industrial Circle, Suite 2211

Lincoln, RI 02865

USA

Factory Authorized Gleason Reel Suppliers
FAST Quotes, FAST Delivery!



ZAMPINI INDUSTRIAL GROUP



Contact Us For Your Gleason Reel Products and Parts Today!

Email Us

Call Us

Fax Us



info@AirToolPro.com

1-800-353-4676
1-401-305-7997

1-401-305-7988



We Respond **FAST!**
Minimize Your Downtime!



Numerous Ways To Get Pricing



Guaranteed Satisfaction!
Excellent Service Since 1987!



Everyday Discounts
Quantity Discounts
Email Specials
Low Price Guarantee