

INSTALLATION and MAINTENANCE INSTRUCTIONS WIRE ROPE FESTOON KITS with NYLON TROLLEYS

⚠ WARNING
Failure to read, understand, and follow these installation instructions may result in damage to festoon or personal injury.

NOTE: The traditional method of wire rope festoon installation is to assemble the entire festoon, including wire rope, on the floor and then lift the assembly to affix both ends of the wire rope. However, because of the ease of installing these festoon trolleys onto a stretched wire rope (see Figures 1 & 2), many users find it easier and safer to install the wire rope prior to hanging the festoon. These instructions outline the latter method.

• TROLLEY INSTALLATION •

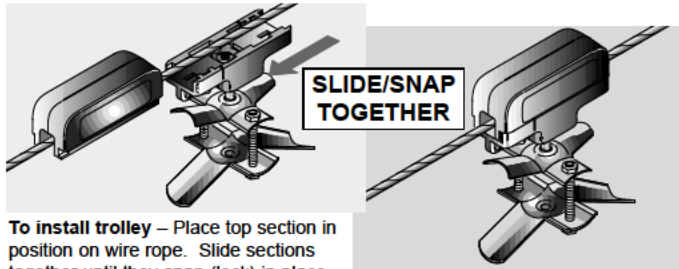

To install trolley – Place top section in position on wire rope. Slide sections together until they snap (lock) in place.
NOTE: Sections may be assembled in only one way. Slide “un-blocked” end into “un-blocked” end. Do not force.

Figure 1

• TROLLEY REMOVAL •

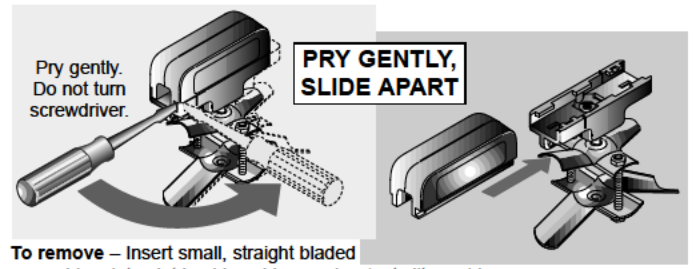

To remove – Insert small, straight bladed screwdriver into slot beside cable opening (not slit on side of trolley) and pry gently as shown above. Do not turn screwdriver. Slide Apart.

Figure 2

INSTALLATION

STEP 1– Mount tension brackets or other suitable device for holding stretched wire rope. See Figure 3.

⚠ WARNING
Wire rope mounts must be able to withstand minimum 1050 lbs.(473kg) lateral force. Improper mounts could give way, causing damage or personal injury.

STEP 2– Install eye-bolts in tension brackets with end clamp on fixed cable end of system only. See Figure 3. Eye-bolt should protrude maximum 0.25”(6mm) through nut (Fig. 4).

STEP 3– Slide rubber bumper onto wire rope. Thread wire rope through eye-bolt on one end of system. Install thimble in loop. Secure wire rope with two (2) cable clamps. See Figure 3. Repeat on other end, pulling wire rope as tight as possible before securing.

STEP 4– Tighten wire rope by turning nuts on eye-bolts. See Figure 4.

STEP 5–Install tow bar on crane or moving machine with slot in tow bar facing downward. End of tow bar must be beneath wire rope and extend beyond wire rope minimum of 2”. Affix tow clamp to under side of tow bar. See Figure 5.

STEP 6– Lay-out trolleys on floor. Install cable or hose in trolley hangers allowing for: 1–Three foot loop depth. 2–One additional loop between first intermediate trolley and end clamp. 3–One additional loop between last trolley and tow clamp. 4–Length at each end for hook up. Tighten clamps until just snug.

STEP 7– Slide bumper to fixed cable end of wire rope. Raise assembled festoon to wire rope and attach trolleys as shown in Figure 1.

STEP 8– Affix cable or hose to end clamp and tow clamp and complete hook-up. Test festoon by moving thru full Active Travel. Adjust loop depth as required for best operation.

STEP 9–Tighten clamps to secure cable or hose.

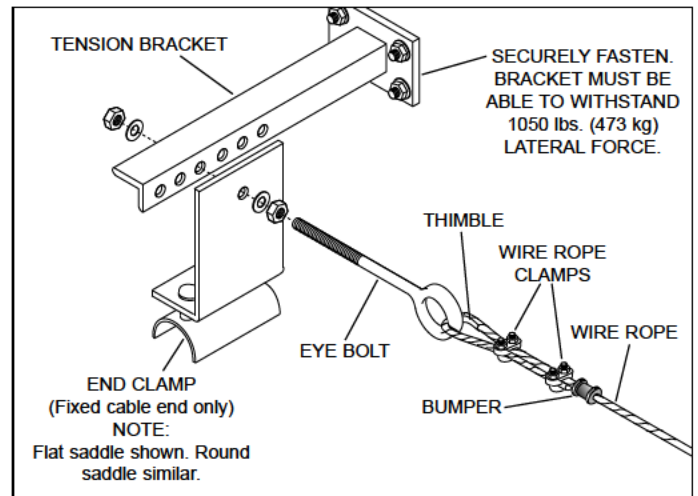

Figure 3

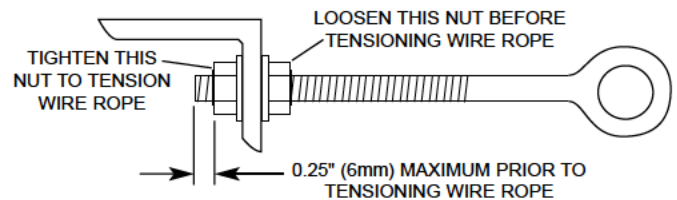

Figure 4

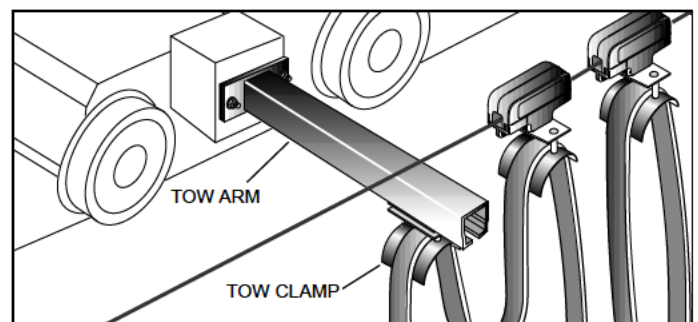
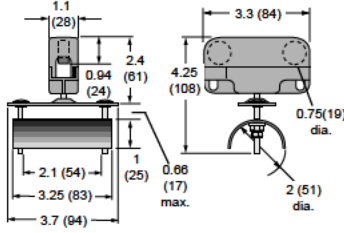

Figure 5

PARTS LIST

FLAT CABLE FESTOON COMPONENTS



**TROLLEY
#3298T43**

Description: Fiberglass reinforced molded nylon with zinc plated steel cable clamp.

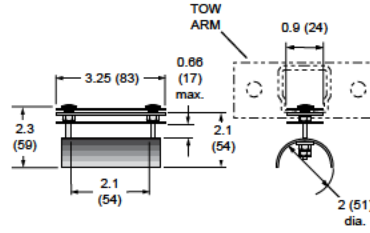

**TOW CLAMP
#3298T49**

Description: Steel with zinc plating.

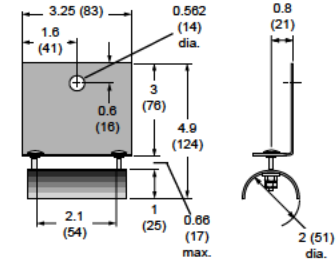

**END CLAMP
#3298T46**

Description: Steel with zinc plating.

ROUND CABLE & HOSE FESTOON COMPONENTS

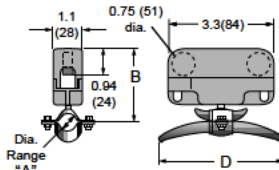

TROLLEY

MODEL NUMBER	"CABLE O.D. "A" in. (mm)	"B" in. (mm)	"D" in. (mm)
3298T41	0.60-0.94 (15-24)	2.6 (66)	3.86 (98)
3298T42	0.95-1.25 (24-32)	2.9 (74)	5.0 (127)

Description: Fiberglass reinforced molded nylon with zinc plated steel cable clamp.

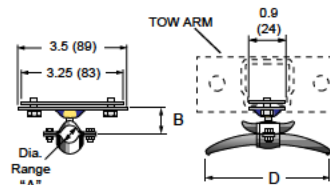

TOW CLAMP

MODEL NUMBER	"CABLE O.D. "A" in. (mm)	"B" in. (mm)	"D" in. (mm)
3298T47	0.60-0.94 (15-24)	1.44 (37)	3.86 (98)
3298T48	0.95-1.25 (24-32)	1.7 (43)	5.0 (127)

Description: Steel with zinc plating.

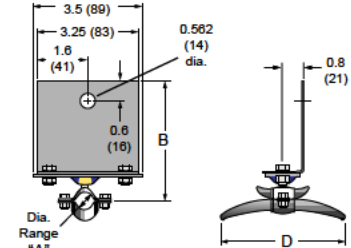

END CLAMP

MODEL NUMBER	"CABLE O.D. "A" in. (mm)	"B" in. (mm)	"D" in. (mm)
3298T44	0.60-0.94 (15-24)	4.25 (108)	3.86 (98)
3298T45	0.95-1.25 (24-32)	4.5 (114)	5.0 (127)

Description: Steel with zinc plating.

Tension Bracket #3298T51

Anchor ends of wire rope and fixed end of festoon.

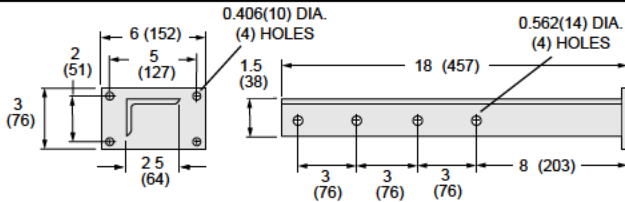
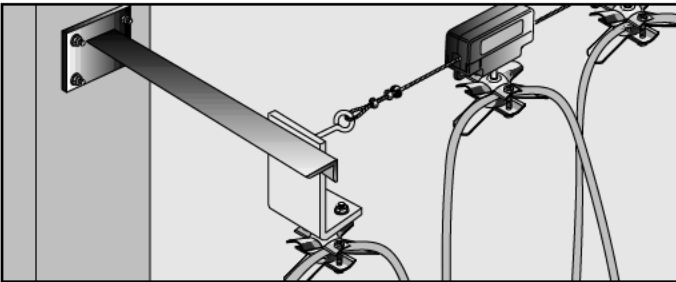

Tow Arm #3298T52

Use on moving end of festoon with Tow Clamp (above).

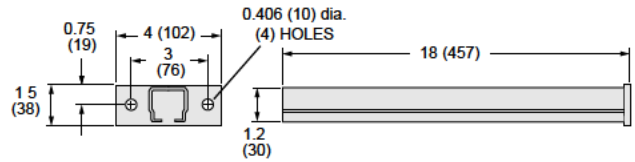
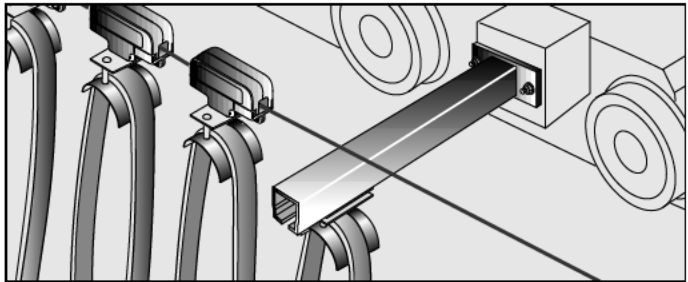

Workplace Solutions

600 South Clark St.
Mayville, WI 53050
Phone: 920-387-4120



Zampini Industrial Group

Trusted Industrial Suppliers Since 1986

85 Industrial Circle, Suite 2211

Lincoln, RI 02865

USA

Factory Authorized Gleason Reel Suppliers
FAST Quotes, FAST Delivery!



**ZAMPINI
INDUSTRIAL
GROUP**



Contact Us For Your Gleason Reel Products and Parts Today!

Email Us



info@AirToolPro.com

Call Us



1-800-353-4676
1-401-305-7997

Fax Us



1-401-305-7988



**We Respond
FAST!**
Minimize Your
Downtime!



**Numerous
Ways To
Get Pricing**



**Guaranteed
Satisfaction!**
Excellent Service
Since 1987!



**Everyday Discounts
Quantity Discounts
Email Specials
Low Price Guarantee**