

**INSTALLATION & MAINTENANCE INSTRUCTIONS**

**50 lb. CAPACITY JIB KIT**

**INSTALLATION**

1. Determine the required/desired location for the jib and consider the height and the boom's arc travel to allow for clearance.
2. Provide an adequate column anchor system
  - a. For a ceiling mounted jib calculate jib weight and max load plus a 7-9 times safety factor (a generally accepted industry standard) to determine a suitable structural support. Provide/install safety chain/cable from the column's forged eyelet to the support structure.
  - b. For a floor mount jib refer to the foundation recommendation drawing - Figure 1.

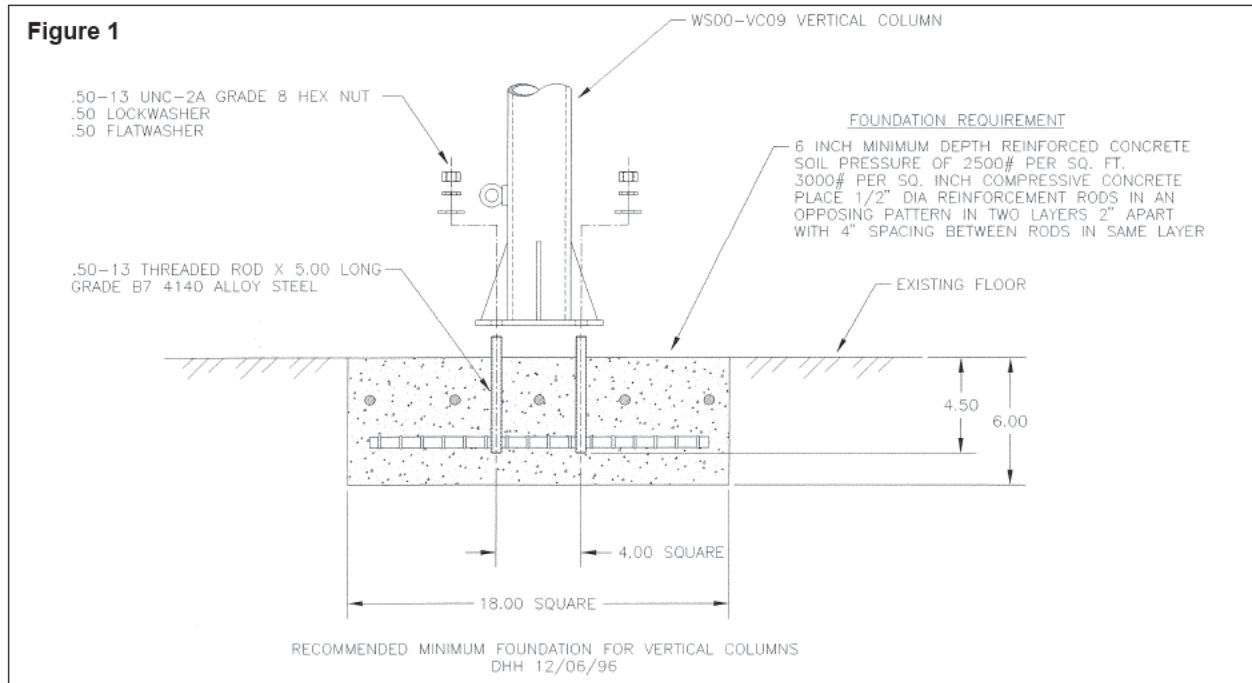

3. Mount the column to the support or foundation using 1/2" hardware and tighten to a torque value of 50-ft/lb for grade 2 and 75-ft/lb for grade 5. Shim or grout as needed to achieve 'plumb'.
4. Locate boom height and attach to column using U-bolts provided which are 3/8-16 UNC-2A and tighten nuts to a torque value of 20-ft/lb - Figure 2.
5. Install end clip, trolleys and end stop into boom's rail. Be sure to install the thru-stop-bolt into the end of the boom. Do NOT over-tighten as not to deform the rail.
6. Check function and clearances, apply load and commence use.

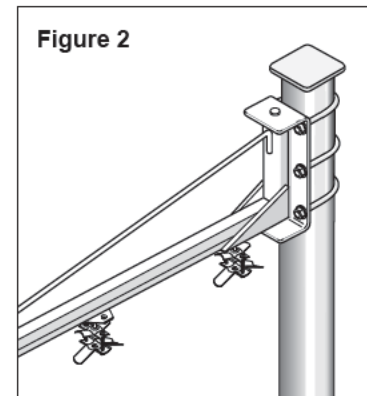

**SPARE PARTS**

**W5S-BMBK - Jib Pivot Bracket / Pin Kit**  
Includes bracket, pivot pin and bronze bushings

## MAINTENANCE

A semi-annual visual inspection should be performed to ensure functionality and integrity of unit. Below are recommended check points:

### 1) Column Base, Floor Mount

- a. Visually inspect the column base plate for material fatigue, stress cracks or fracture and repair or replace as necessary.
- b. Check tightness of hardware and re-torque as required.

### 2) Column Base, Ceiling Mount

- a. Visually inspect the support structure for fatigue, stress cracks or fracture and repair or replace as necessary.
- b. Visually inspect the column base plate for material fatigue, stress cracks or fracture and repair or replace as necessary.
- c. Check tightness of mounting bolts and nuts and re-torque as required or replace.
- d. Ensure safety chain anchor is suitable.

### 3) Boom Mount and Pivot

- a. Visually inspect the mounting U-bolts and nuts for fatigue or fracture and replace if necessary.
- b. Check tightness of the U-bolt nuts and re-torque as required.
- c. Visually inspect the pivot pin, bracket and bronze bushings for wear and dirt build-up. Clean parts with air blast and/or shop rag. If there is little to no wear apply a small amount of SAE 841 Type 1 Class A oil to pivot pin and bronze bushings. If there is noticeable or excessive wear replace as required.
- d. Visually and manually inspect trolleys for travel function. Replace if wear is excessive or if traverse is impaired.
- e. Ensure end stop is in place. Re-locate and/or re-tighten hardware to suit.
- f. Ensure thru-stop-bolt is present and tight

Adherence to the above check list and maintenance procedure is imperative to improve performance and longevity of the column, boom and components, as well as provide a safe work environment. Consult factory with questions.

## WARRANTY

*Gleason warrants for a period of twelve (12) months after date of shipment, all goods manufactured by it to be free from defects in material and workmanship. If, within such warranty period, any such goods are proved, to Gleason's satisfaction, to be defective, such goods shall be repaired or, at Gleason's option, replaced f.o.b. Gleason's factory, without charge. Gleason's obligation hereunder shall be confined to such repair or replacement and shall be further conditioned upon Gleason receiving written notice of any alleged defect within 10 days after its discovery and, at Gleason's option, the return of the alleged defective goods to Gleason, f.o.b. its factory.*

*The foregoing warranty shall not apply to goods not manufactured by Gleason, or to goods which shall have been repaired or altered by others than Gleason so as to, in Gleason's judgement, adversely affect the same, or which shall have been subject to other than normal use of service, negligence, accident, or improper maintenance care, or storage. With respect to goods furnished but not manufactured by Gleason, the warranty obligations of Gleason shall in all respects conform and be limited to the warranty extended to Gleason by the supplier. The foregoing warranty is in lieu of all other express or implied warranties (except of title) and of all other obligations of Gleason.*



**Workplace Solutions**

A DIVISION OF GLEASON REEL CORP.

**Gleason Reel Corp.**  
600 South Clark Street  
Mayville, WI 53050  
PH: 920-387-4120  
[www.hubbell-gleason.com](http://www.hubbell-gleason.com)

PN 630600



# Zampini Industrial Group

Trusted Industrial Suppliers Since 1986

85 Industrial Circle, Suite 2211

Lincoln, RI 02865

USA

**Factory Authorized Gleason Reel Suppliers**  
**FAST Quotes, FAST Delivery!**



**ZAMPINI  
INDUSTRIAL  
GROUP**



Contact Us For Your Gleason Reel Products and Parts Today!

Email Us



[info@AirToolPro.com](mailto:info@AirToolPro.com)

Call Us



1-800-353-4676  
1-401-305-7997

Fax Us



1-401-305-7988



**We Respond  
FAST!**  
Minimize Your  
Downtime!



**Numerous  
Ways To  
Get Pricing**



**Guaranteed  
Satisfaction!**  
Excellent Service  
Since 1987!



**Everyday Discounts  
Quantity Discounts  
Email Specials  
Low Price Guarantee**